

GBZ Print Service – Spare Parts for the Printing Industry



# Impressive Diversity – GBZ Print Service

Due to a reorientation in the printing and packaging industry, as of 01.01.2012 GBZ Mannheim GmbH und Co. KG outsourced its printing industry division into a separate company: GBZ Print Service GmbH & Co. KG. Thanks to our highly motivated and competent staff's many years of experience in the printing industry, we are a reliable partner with custom-tailored solutions and the highest level of quality.

As printing and packaging industry specialists, we always have the right product on hand for you. The Print Service boasts an extremely diverse product range.

The range produced at GBZ includes many spare parts for all manufacturers and brands. Whether for cutting, perforating or folding – we will deliver to you the right product for your machine.

Equipped with the latest production equipment, our machinery guarantees the highest accuracy in production. Precision and very tight tolerances are our everyday standard. The DIN ISO 9001 certification of our GBZ manufacturing ensures the quality of your spare parts at all times.



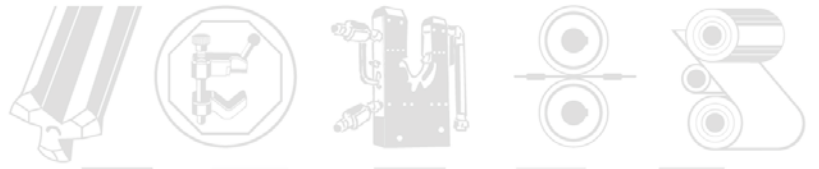

## *The art of precision*

With support from our design department, we produce parts tailored to your individual requirements. Even complicated parts are no problem for us. Having trouble finding a solution? We'll find one together with you..

We are pleased to be your competent and flexible partner today and in the future!

And that's not all. In addition to our variety of spare parts, we offer you many other services such as:

- Installation of spare parts
- Maintenance offers
- Project consultation

# GB<sup>®</sup> ZB





- Guaranteed tensile load of 120 kg -

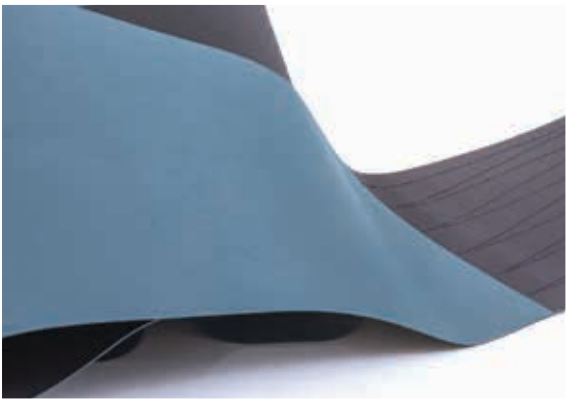



## Web Up Kites

GBZ Print Service produces web up kites for use in the printing presses of all manufacturers.

- Web up kites with and without bowden cable - in various lengths and shapes
- Heat-resistant web up kites
- Web up kites with magnet
- Web up kites according to customer sample
- Modified web up kites according to customer requirement



# Equipment for Washing Systems and Dampening Units

The printing unit requires a number of accessories that are covered by our variety of products for all makes and types of machines. These in particular include:

- **Brushes**

We supply you with suitable brush rollers for washing equipment of blanket washers with the original fill material and the right journal or closing rings, manufactured according to OEM specification.

- **Wash clothes**

Dry and wet wash clothes in different qualities.





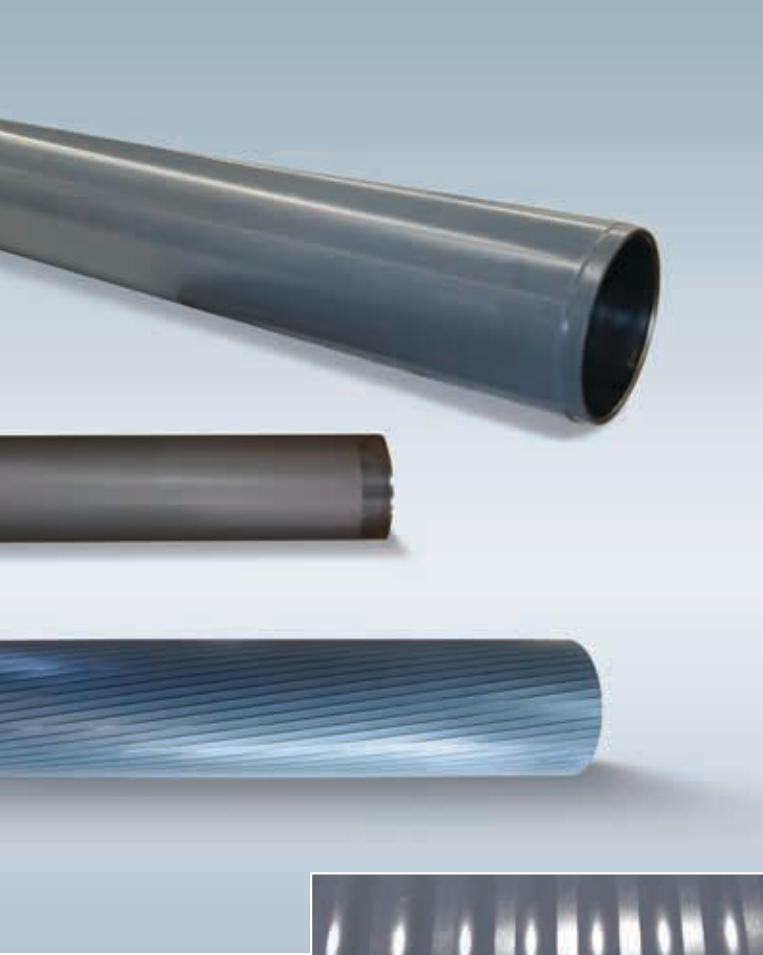

# Printing Unit Accessories

## **Ductors, film rollers, distribution cylinders, chrome and ink rollers**

We repair and manufacture rollers for all the different specifications with coatings such as ceramic, Rilsan®, chrome, rubber and other materials. ®Rilsan is a registered trademark of the company Arkema.

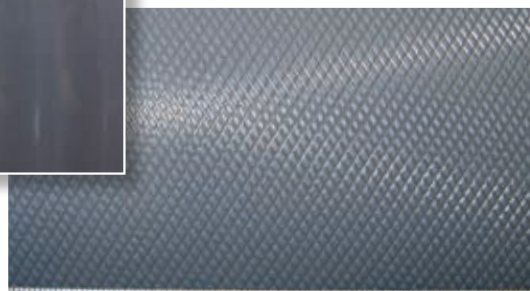
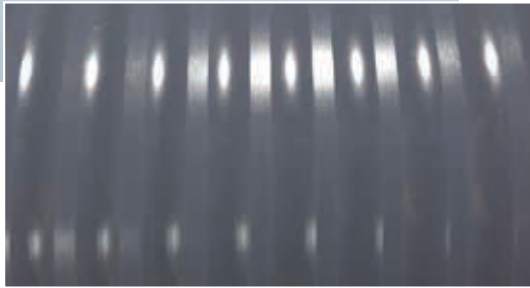

## **Bearer ring felts**

GBZ Print Service uses a special material for all common bearer ring felts, which guarantees optimum functioning. The design is made by dimensions according to drawing or customer's sample, on request with slots or holes.





# Drag, Transport and Cutting Rings, Draw and Tape Rollers

The repair and refurbishment of worn rings as well as the new production of various tension elements using different surfaces and versions is part of our standard programme.

High-quality, chromium-alloyed tool steels are used in the process. You are provided with CNC-machined, knurled or coated versions.

We are able to cover the entire range of rollers required in the printing industry rolls thanks to our great variety of coating options. The core materials and surface coatings vary depending on the requirement profile – after all, very good printing results can only be achieved with high-precision rollers in terms of concentricity and surface finish.

The roller cores can be made of steel, aluminium, carbon-fibre reinforced plastic (CFRP) or glass-fibre reinforced plastic (GRP). We also deliver rollers according to your drawings and specifications with respect to core material and surface coating.



# Vulcollan® Components

GBZ Print Service provides guide rails for sheet dampening for all common web offset presses made of homogeneous and cellular Vulcollan®. These parts are produced with optimised performance characteristics through material combinations in the following versions:

- Homogenous Vulcollan®
- Combined Vulcollan® (homogeneous and cellular)
- Combined Vulcollan® (made of spring steel and cellular)

The mouldings have a very high dynamic load capacity, high tensile strength and very high tear resistance as well as excellent thermal stability.

®Vulcollan is a registered trademark of the company Bayer AG.





## Draw, Sliding and Transport Rollers

Our draw rollers are produced from material combinations with optimised performance characteristics. They stand out by a very high dynamic load capacity and maximum operational smoothness. They are also extremely resistant to wear. The following versions are possible:

- Steel / aluminium core with rubber coating
- Steel / aluminium core with polyurethane coating
- Steel / aluminium core with Vulcollan® coating

Our draw- or transport rollers for further processing can be used in the following production units: saddle stitching drums, cutting drums, transport chains and transport clamps.

®Vulcollan is a registered trademark of the company Bayer AG.

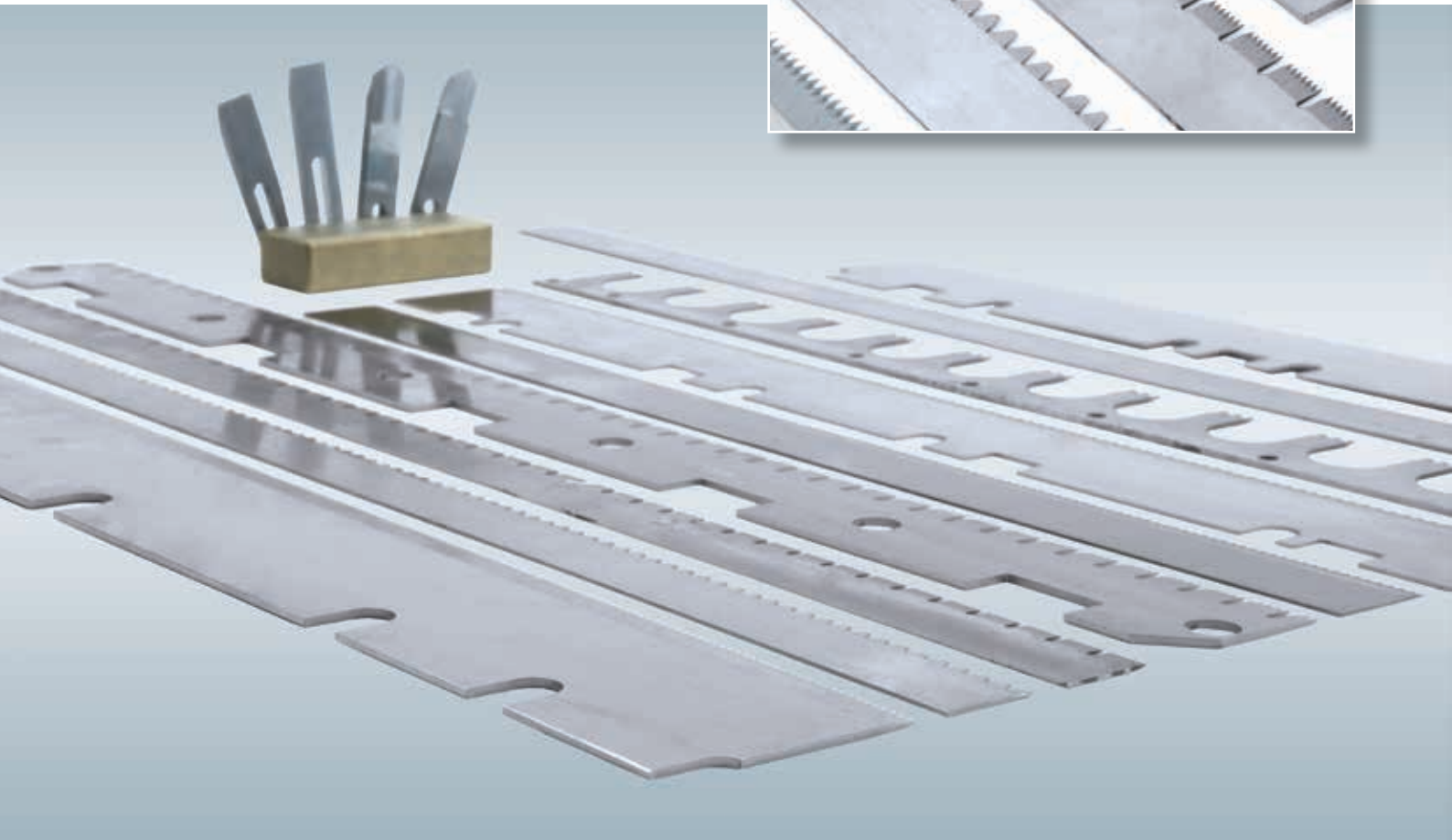
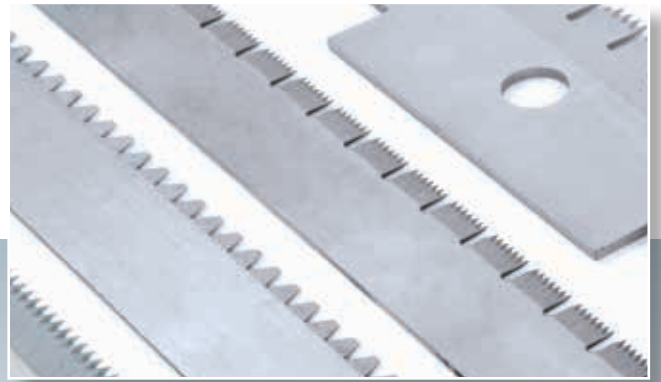
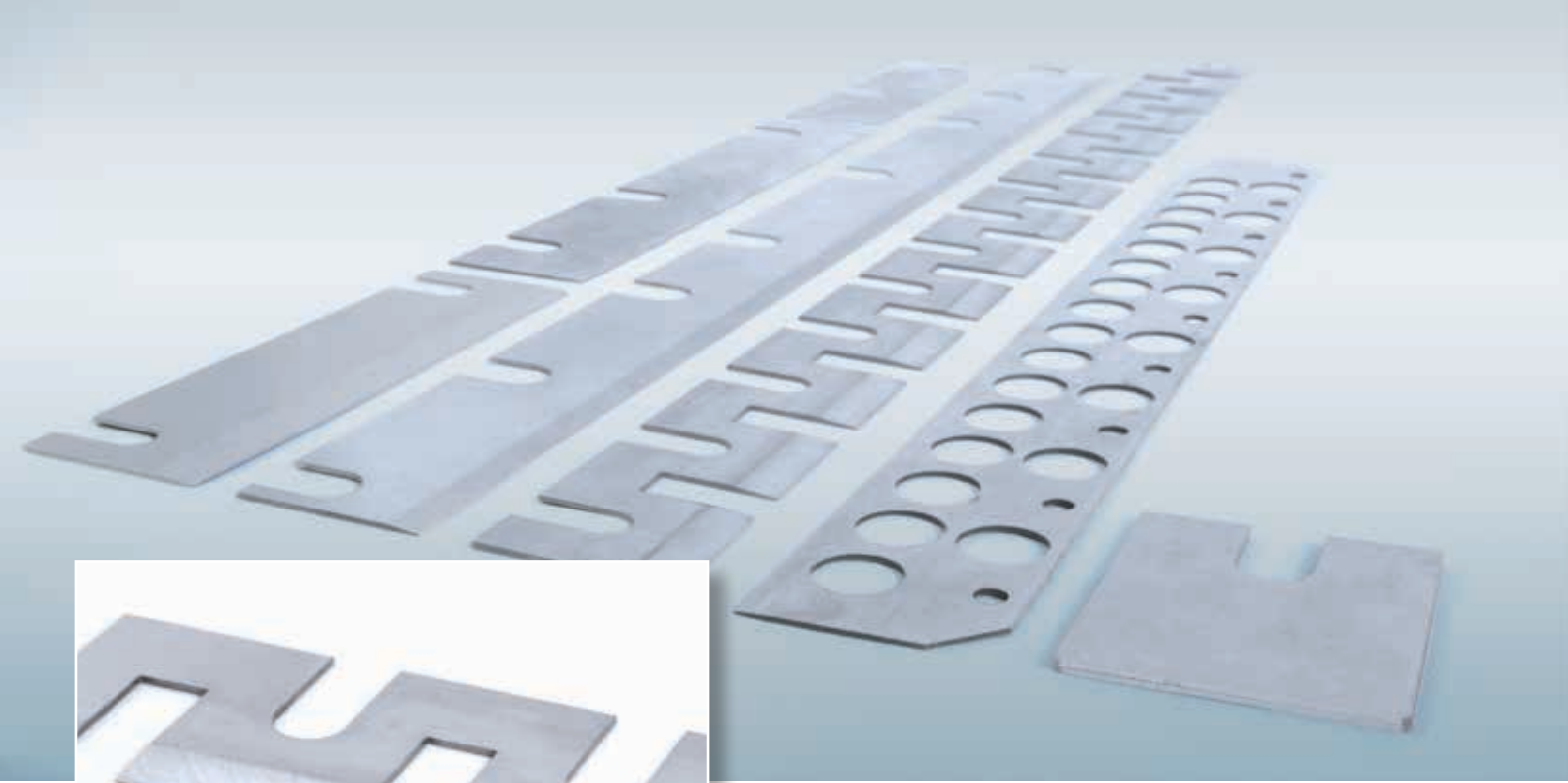

# Folding, Cutting and Circular Blades

- **Folding blades**

We supply folding blades in a standard version, with simple and double chamfers as well as gaps and holes. On special request by the customer, they can be produced with different coatings or special, usage-based materials, too.

- **Cutter blades / perforating blades / rotary cutter blades / book spine milling cutters**

You are provided with cutting blades for sawing and for perforating cuts. Tooth pitches and punch-outs according to drawing or customer sample are always possible. For all common rotary cutters and book spine milling cutters, GBZ Print Service produces the corresponding replacement blades – also according to drawing or customer sample.

- **Circular blades / perforating circular blades**

Our circular blades are made of steel, HSSE, special steel, steel with carbide coating or solid carbide. Desired outer diameters of 20–350 mm as well as chamfers, grooves, holes and tooth shapes are possible at any time according to drawing or customer sample.

- **Grinding service**

We resharpen and straighten your knives for long time use



# Pins and Pin Holders

For almost all common folders, the right pins and their holders are directly available in our warehouse. Custom-made products can be manufactured on request according to drawings or customer samples.



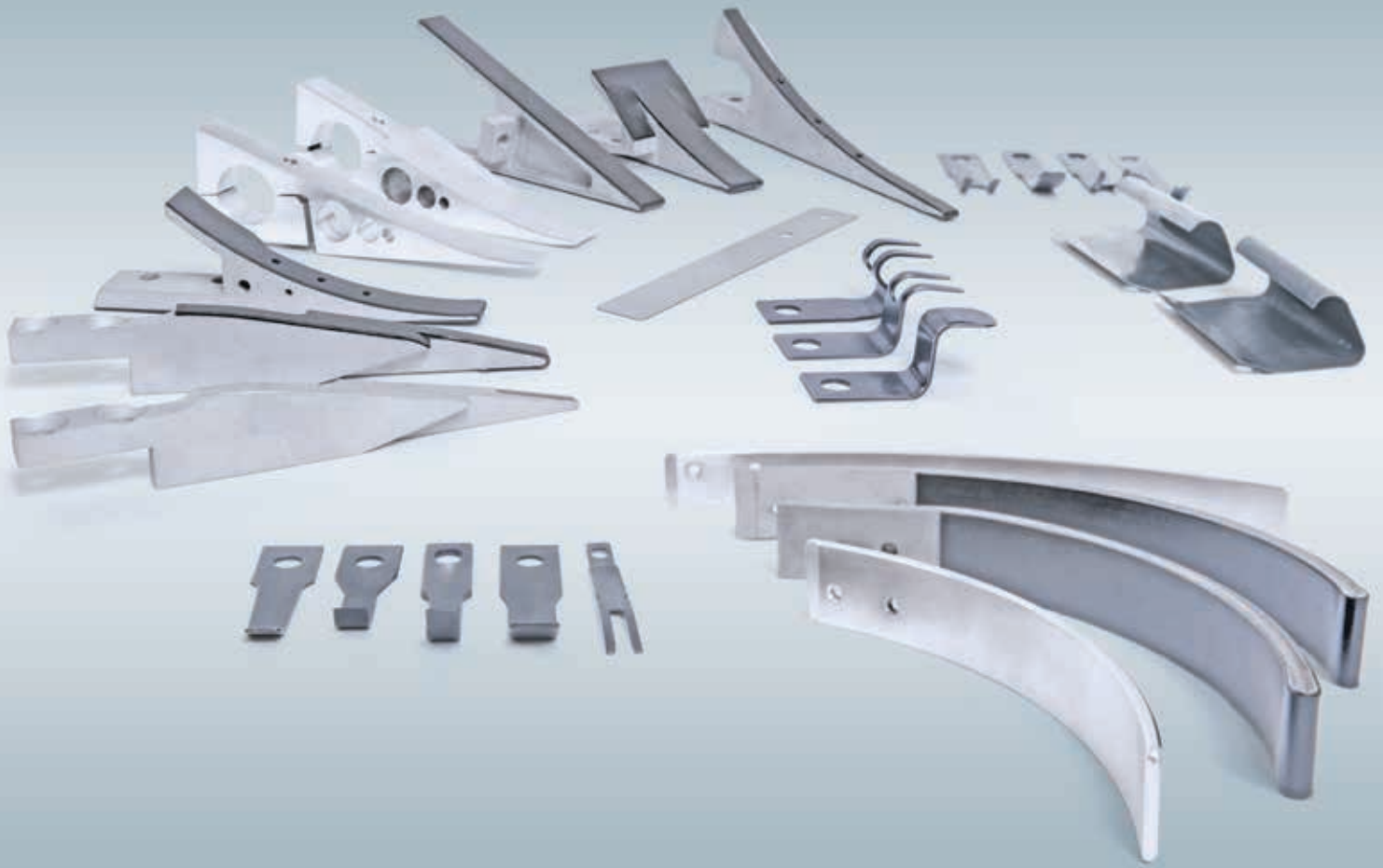

## Guides, Paddles, Grippers

Tongues are reprocessed at GBZ Print Service based on the degree of wear. For new production, different materials such as plastic, steel, aluminium, polyurethane or teflon is used, depending on the application and requirements. Various coatings are also possible.

All folders, grippers and paddles can be manufactured according to drawing or customer sample. Depending on the type, they are made of either of spring steel or alloy tool steel and coated as needed.



## Plastic Parts

GBZ Print Service offers all mouldings made of thermoplastic material. Cutting-edge production technologies allow technical products that meet the highest quality standards when using different machines.



# Special Parts

The production of individual parts is likewise a matter of course. Here is an extract of our various options:

- Folding tables
  - Barell for replacement in reel splicers
  - Gears
  - Holders
  - Former noses
  - Eccentric bolts,
- etc.

Our design and manufacturing is at your disposal. We manufacture all mechanical parts according to samples, drawings or personal requirements.

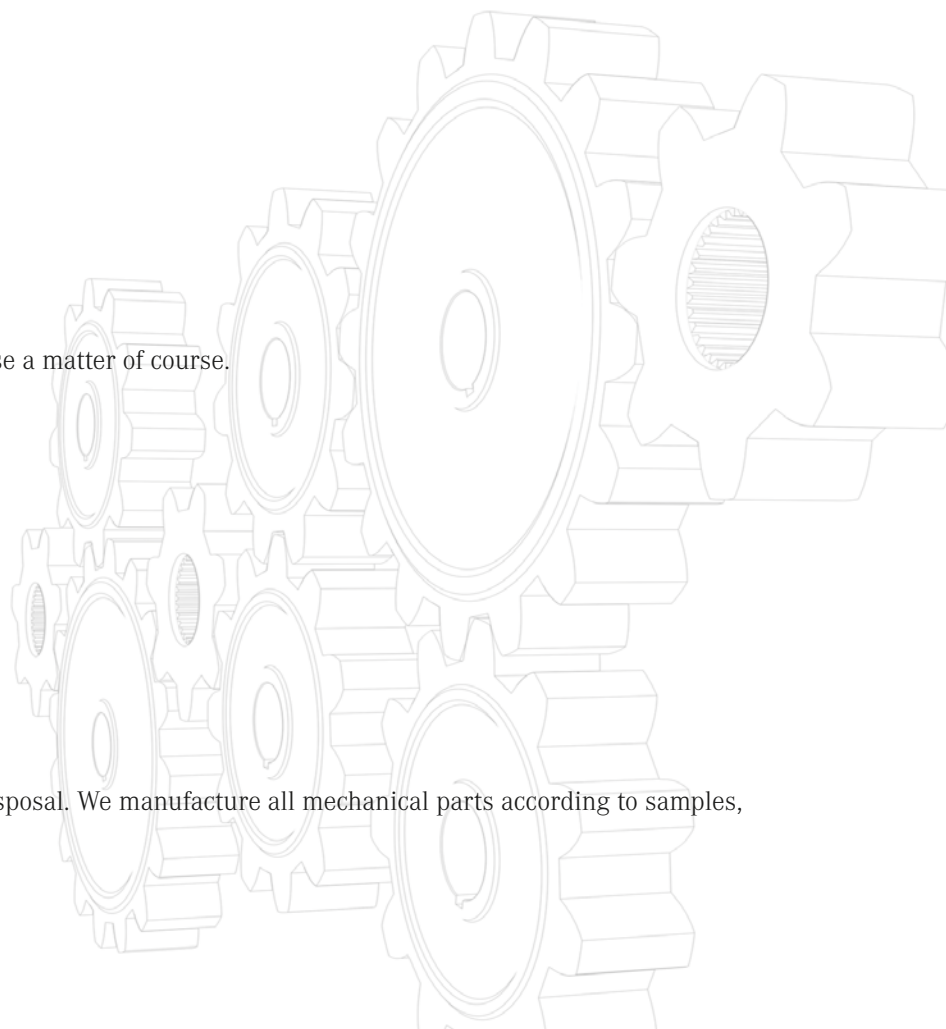



# Cutting Bars

They are an important wear part for the entire cutting system. GBZ Print Service's cutting bars are available in all standard sizes, qualities and any hardness from stock. For example, made of:

- Vulcollan® 92° Shore
- Polyurethan 80° / 85° / 90° / 95° Shore

The highly abrasion resistant and tough material has high cut resistance and thus an extremely long service life. On customer request, we shorten the cutting bars and chamfer the longitudinal sides.

Vulcollan® is a registered trademark of the company Bayer AG.

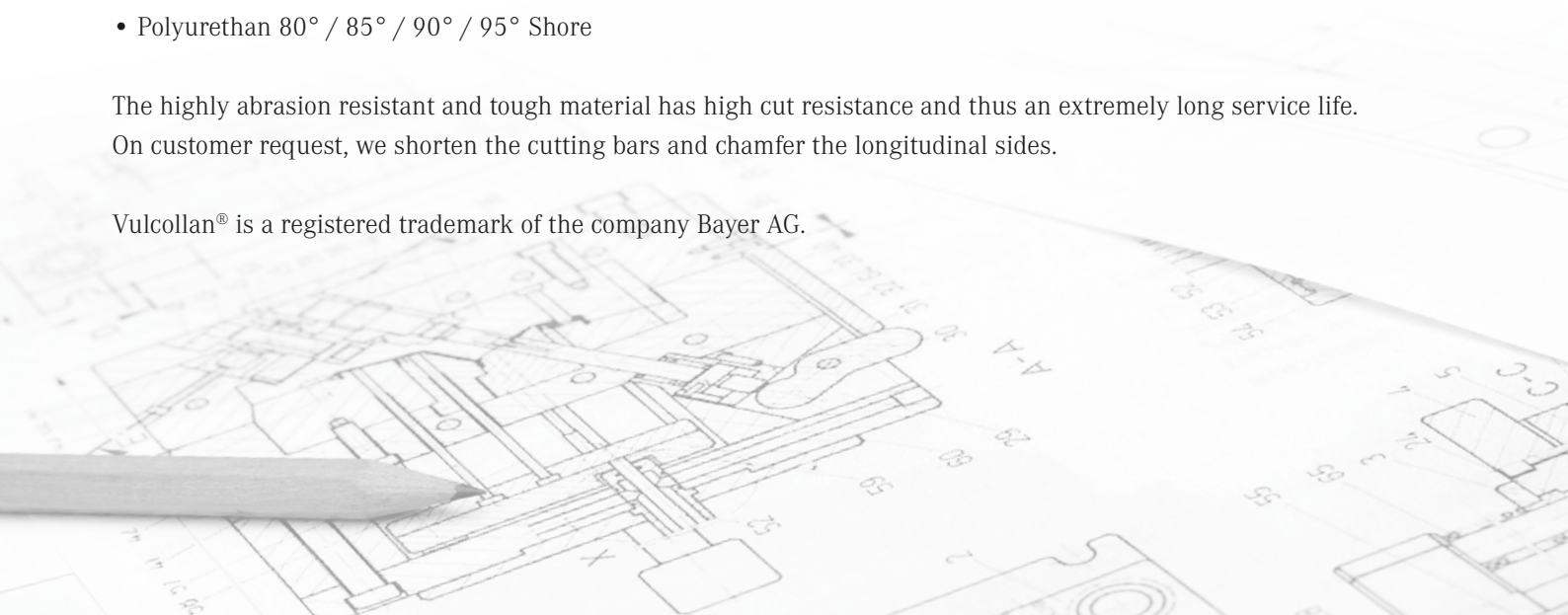



# Folding Jaws

A reliable and accurate folding process requires the highest precision in production and preparation. GBZ Print Service manufactures folding and counterfolding plates in a wide variety of coatings: Tungsten Carbide, ceramics or Vulkollan® while maintaining the tightest tolerances in terms of thickness, height and parallelism.

## **Your old folding flaps are worn out?**

A repair and reconditioning of your products with new metallic coating or new Vulkollan®, is also possible after technical inspection. This saves resources and your wallet.

Vulkollan® is a registered trademark of Bayer AG.

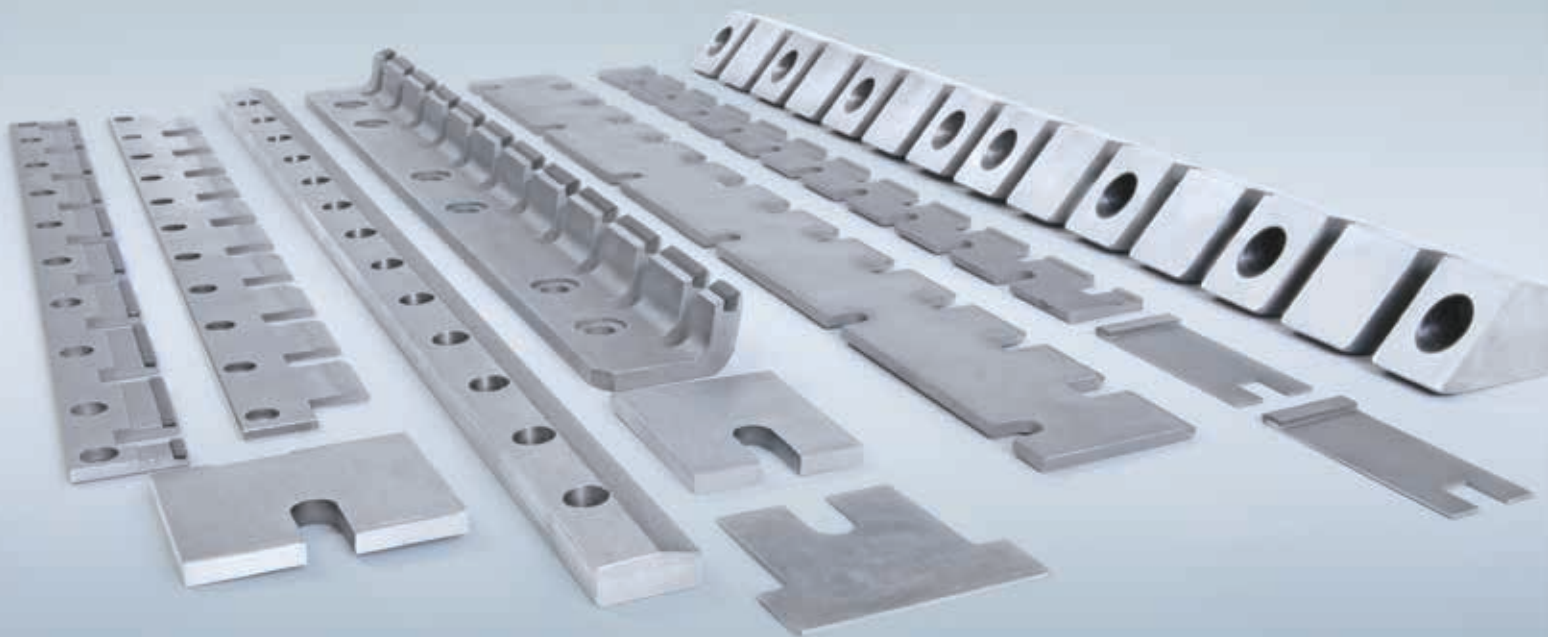

# Stitchers

At our Frankenthal plant, we produce wear and spare parts for all common rotary and saddle stitchers. We offer a variety of designs for different wire thicknesses and staple widths:

- Pistons/plungers
- Wire bending rolls
- Wire feeding rolls
- Adjusting wedges
- Wire rest
- Wire rest with carbide
- Wire feeding jaws
- Wire cutting jets
- Clamping blocks
- Guides
- Stable guides
- Stitch forks
- Side plates
- Leaf springs



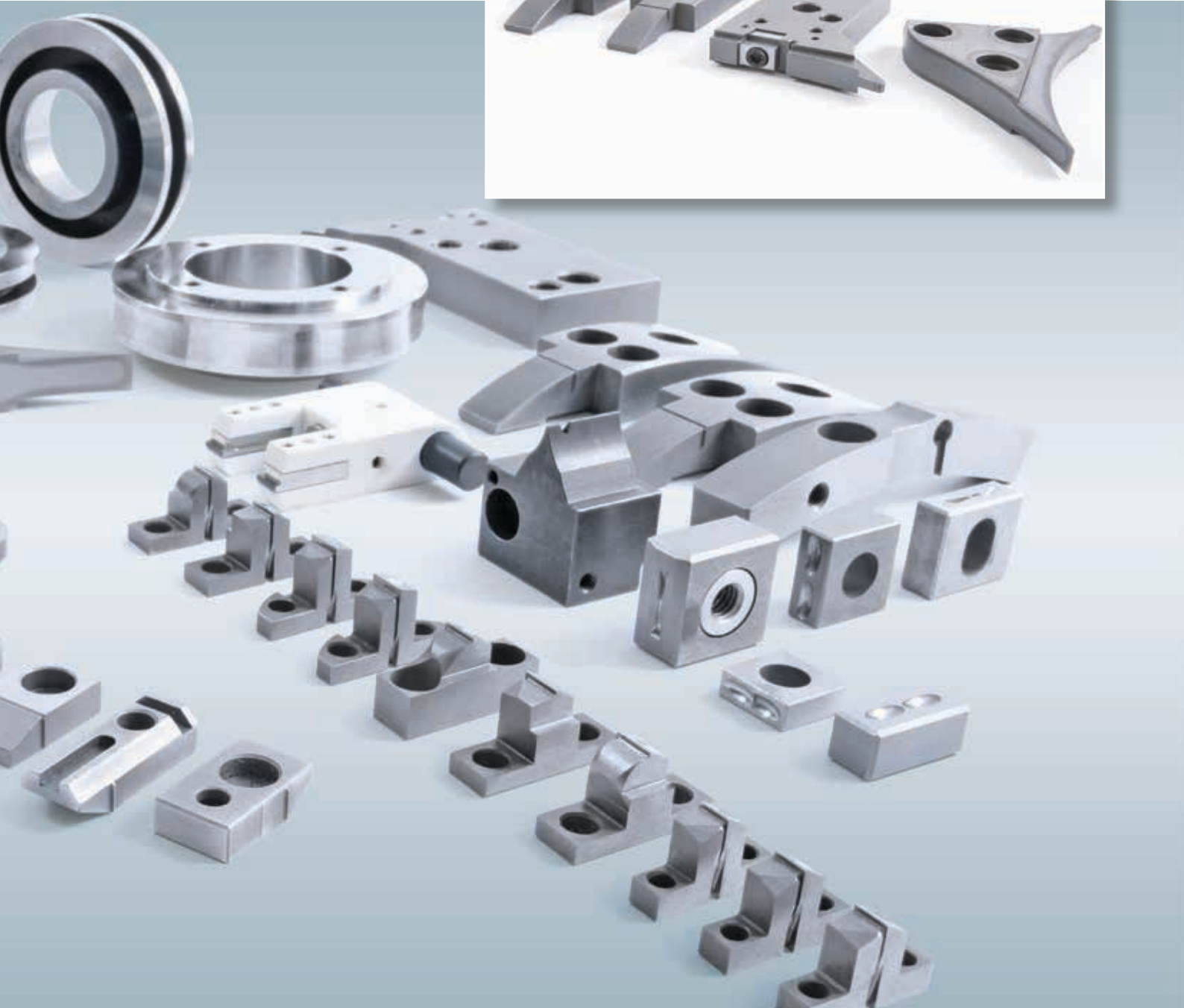



## Transporting, Perforating, Folding and Cutting.

We also manufacture parts for further processing. Whether rolls for transporting paper or various knives for cutting and perforating, we always have the right product available.

We would also be pleased to create a new or modified component according to your wishes. Please contact us.





# Sheetfed and Packagingmachines

There was nothing for you? Perhaps you have a need for parts for sheets and packaging machines. We manufacture for you the most different parts from metal, plastic and all common materials. Also special designs according .to customer requirements are no problem.

Sealing squeegees, washing squeegees, perforated belts, brushes, suction cups and much more. Convince yourself of our product range and variety







# Repair of Electrical Parts

Repair of frequency converters, servo motors, programmed controls, terminals and industrial PC, Inverters, Encoders, Tachometers, Cards, Terminals etc. All common brands like ABB, Baumüller, Bosch Rexroth, Siemens, Lenze, Elau, B&R, Allen Bradley, Schneider, etc.

- Repair on component level with or without circuit diagrams, also for discontinued components
- Replacement of defective components and inspection of solder joints
- Systematic replacement of wearing parts on servo motors
- Exchange of bearings
- Inspection and reading of encoders
- Thorough cleaning

## Our plus:

- Free estimate,
- 6 months warranty on the repair,
- Free disposal in case of uneconomical repair

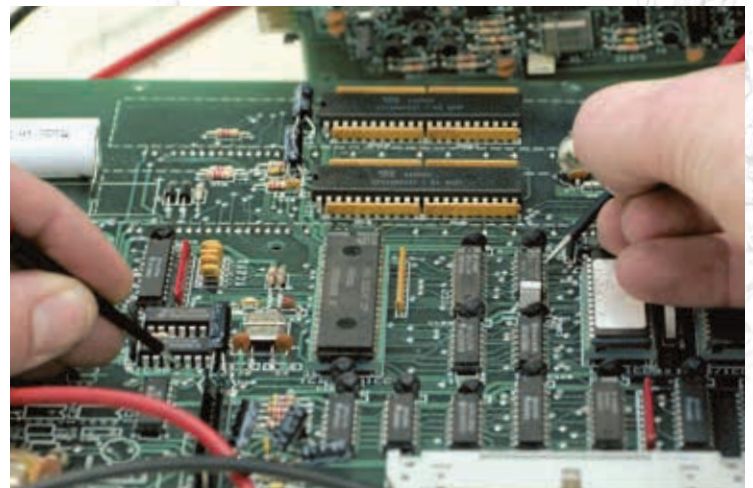

# Services and Maintenance

GBZ Print Service offers its customers around the world extensive repairs, maintenance and overhaul of different manufacturer products. We can offer this service for various assemblies and components:

- Stitchers (KBA, MAN, Tolerans), at customer premises or at our premises in Frankenthal
- Folders (KBA, MAN)
- Printing units (KBA, MAN)
- Blanket washing systems (OxyDry, Elletra, Baldwin, Rotoclean)
- Ink pumps (Betz, Lincoln)

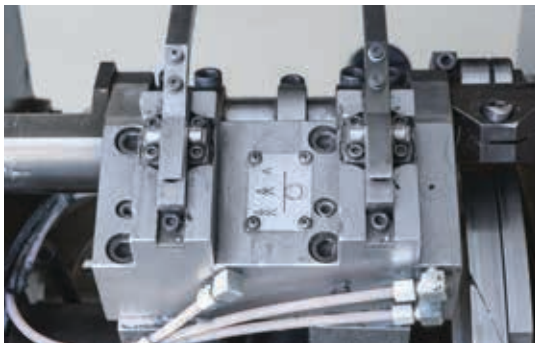

We also advise you on upcoming projects and their explanation and implementation. Our team will always support you. Feel free to contact us.

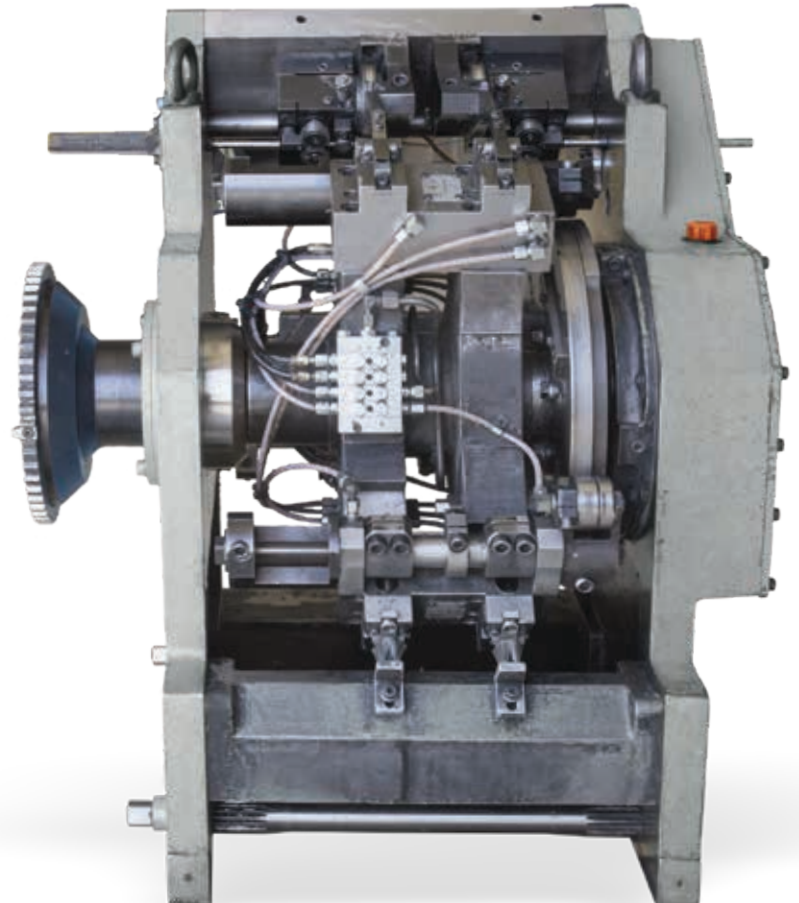

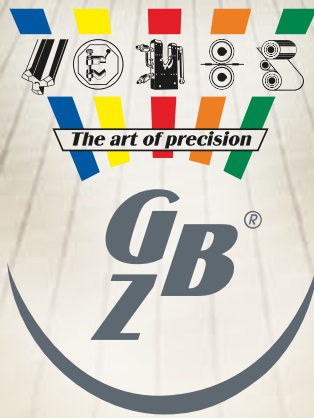

**Uwe Jessberger**, Managing Director  
Phone: +49 6233 37547-42  
Mobile: +49 174 3436077  
Email: [u.jessberger@gb-z.de](mailto:u.jessberger@gb-z.de)

**GBZ Print Service GmbH & Co. KG**  
Adam-Opel-Str. 7  
67227 Frankenthal  
Telefon: +49 6233 37547-0  
Telefax: +49 6233 37547-600  
E-Mail: [printservice@gb-z.de](mailto:printservice@gb-z.de)  
[www.gbz-printservice.de](http://www.gbz-printservice.de)



**Andreas Kraft**, Sales Manager  
Phone: +49 6233 37547-43  
Mobile: +49 174 3436078  
Email: [a.kraft@gb-z.de](mailto:a.kraft@gb-z.de)